

B. W. FOSTER.
MACHINE FOR MAKING CARRIAGE-AXLES.

No. 75,893.

Patented Mar. 24, 1868.

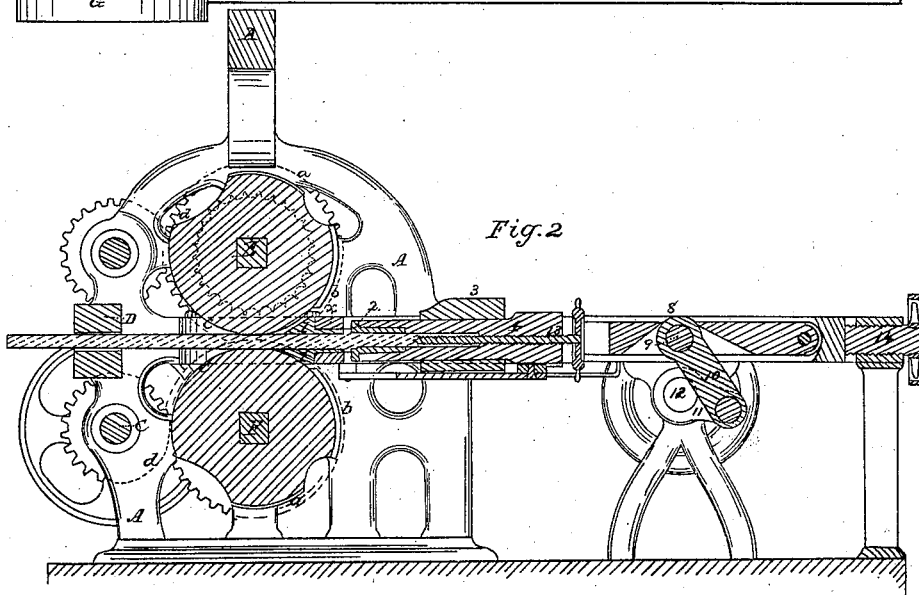
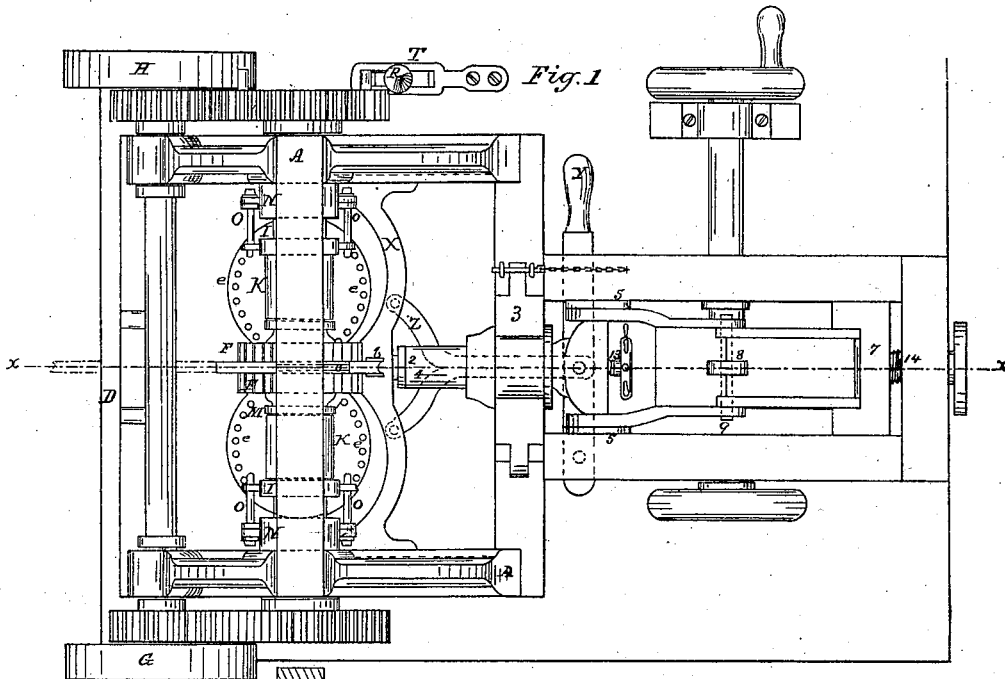

Witnesses
Chas. Roubin
Jno. J. MacLean

Inventor
Benjamin W. Foster
By his atty. Lewis, Knickerbocker

B. W. FOSTER.
MACHINE FOR MAKING CARRIAGE AXLES.

No. 75,893.

Patented Mar. 24, 1868.

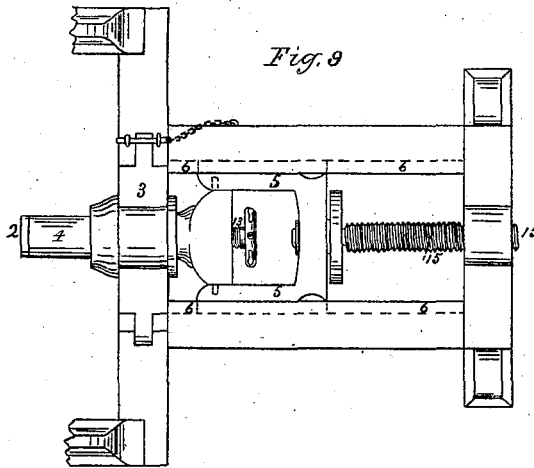
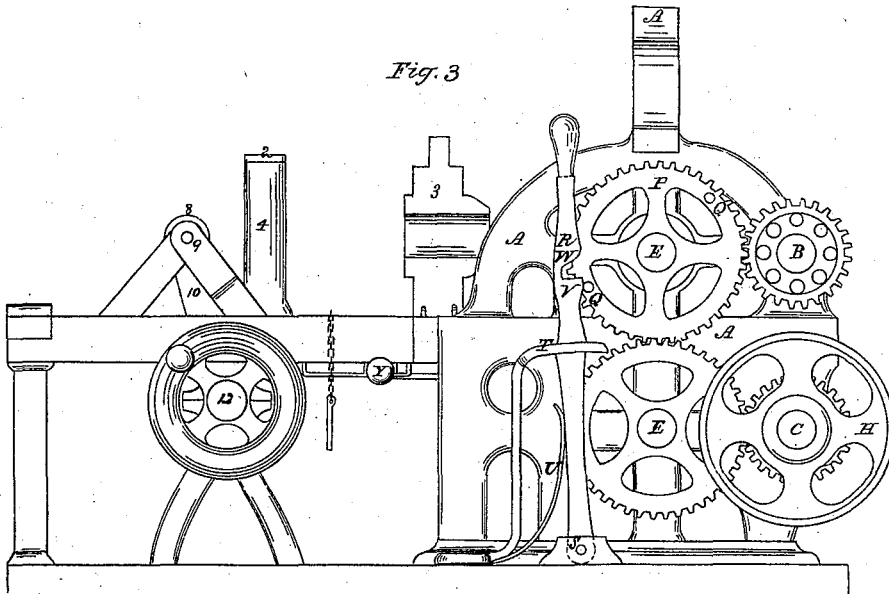

Witnesses
C. A. Roubine
Jno. J. Ralied

Inventor
Benjamin W. Foster
by Chas. H. Husted & Gould
his attys.

B. W. FOSTER.
MACHINE FOR MAKING CARRIAGE AXLES.

No. 75,893.

Patented Mar. 24, 1868.

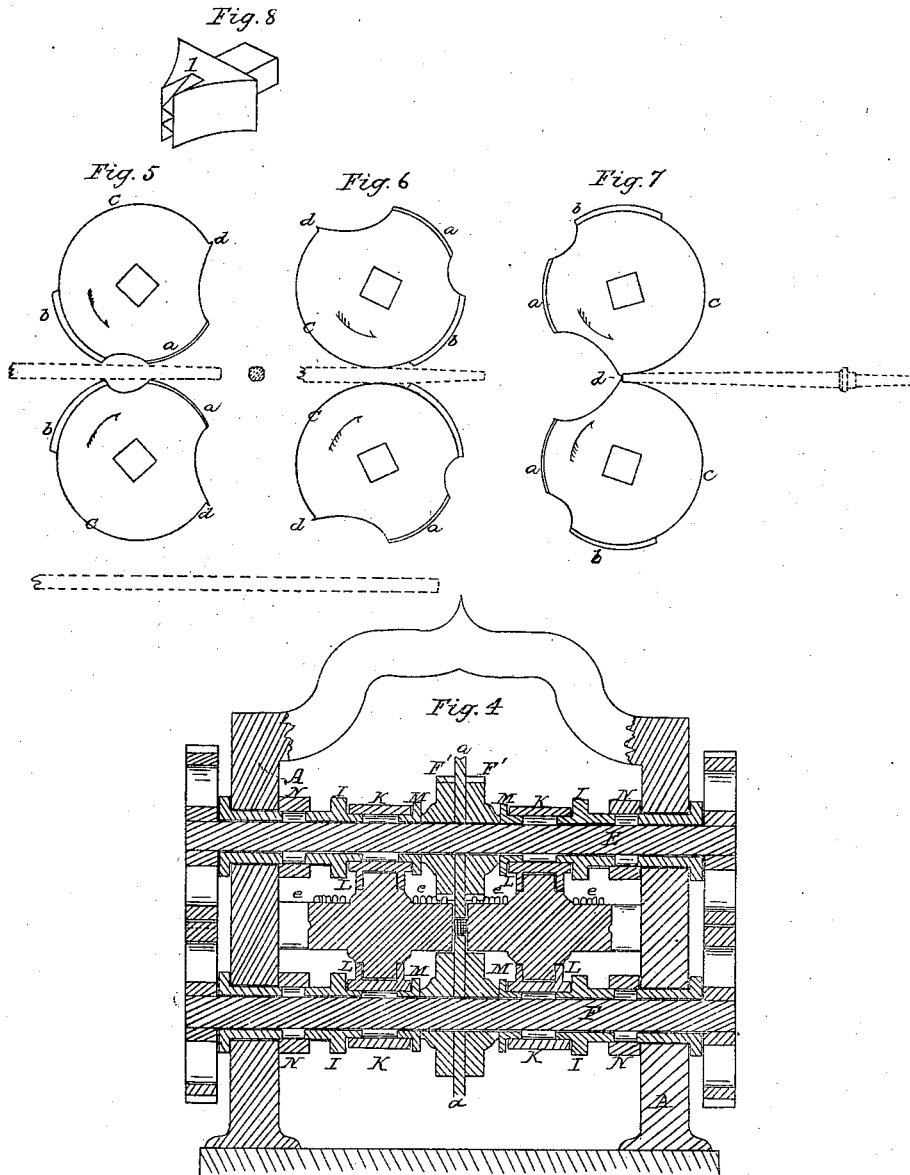

Witnesses:
E. C. G. Gubler
Geo. J. Halsted

Inventor
Benjamin W. Foster
by *his atty.*
Geo. J. Halsted & Co.

United States Patent Office.

BENJAMIN W. FOSTER, OF AUBURN, NEW YORK, ASSIGNOR TO FRANKLIN L. SHELDON AND CHARLES L. SHELDON, OF SAME PLACE.

Letters Patent No. 75,893, dated March 24, 1868.

IMPROVED MACHINE FOR MAKING CARRIAGE-AXLES.

The Schedule referred to in these Letters Patent and making part of the same.

TO ALL WHOM IT MAY CONCERN:

Be it known that I, BENJAMIN W. FOSTER, of Auburn, in the county of Cayuga, and State of New York, have invented certain Improvements in Machines for Making Iron and Steel Axles; and I do hereby declare that the following, taken in connection with the drawings which accompany and form part of this specification, is a description of my invention sufficient to enable those skilled in the art to practise it.

In the manufacture of steel and iron axles, it is now the general practice to manufacture the same with but one journal, one collar, and a short bar, two such pieces, (now generally styled and known by the technical term "axle,") when afterwards united together, with the journals at their outer ends, forming the complete axle, ready for application to the car or vehicle for which it is designed. Such axles have heretofore been made by slow and laborious processes, entirely or mainly by hand-labor.

The object of my invention is to form an axle complete, with its journal, its collar, and its tapering bar, all by a continuous process; and from a single bar of metal, to cut the same off when finished, and repeat the action upon the remainder of the bar of metal; and it consists in the construction of a machine of such capacity, and having such an organism, as that upon feeding into it, as hereinafter described, a heated square bar of metal of the appropriate size, it will, successively, flatten the four corners or edges for a distance sufficient for forming the journal; then round these edges, till they form a tapering cylinder; next, gripe the same in, and compress or upset it lengthwise, between suitable dies, to form the collar, and the swell on the journal, and, at the same time, centre the journal ready for a turning-lathe; next, roll the remainder of the axle to the proper taper; and finally, at the proper point, cut off the finished axle, and discharge it from the machine.

The parts, in minute detail, which contribute to these ends, I will now proceed to describe.

A is a framework, of any suitable kind, having sufficient strength to support and permit the proper action of the working parts. B is the main shaft, which imparts motion to the system of shaping rolls, hereinafter described, and C is a counter-shaft.

D is a cross-bar, through the centre of which is a mouth or opening, into which the bar of metal to be made into axles is first placed, preparatory to being acted upon by the rolls. This mouth is in line with the shaping-space between the peripheries of the rolls, and forms a rest or support for the bar.

E F are two horizontal square shafts, placed one above the other, the upper one, E, having a cog-wheel at each end, meshing into a pinion at each end of the main shaft. The lower shaft, F, has at each end cog-wheels of equal size and number of teeth with those on shaft E, into which they gear, and they also gear with pinions on both ends of the counter-shaft C, these pinions being of the same size as those upon the main shaft.

A driving-pulley, G, is mounted on shaft B, and a counter driving-pulley, H, on shaft C.

At the centre of each of the shafts E and F are rigidly secured two cog-wheels, F', between which are firmly secured, by bolts, pins, or other well-known means, the several removable parts, which, unitedly, make up the roll for shaping the journal, and shaping and tapering the arm, and severing it from the bar.

The periphery of each of these rolls, when the parts composing it are secured in place, is made up of three shaping-parts and a cutting-edge, these several parts in each of these rolls being identical with those in the other. These parts consist of a groove, *a*, for reducing the corners and partially tapering that end of the bar which is to be formed into a journal; another groove, *b*, for still further reducing all corners and edges, and producing the finished tapering journal; a flat but slightly eccentric cam, *c*, gradually increasing in diameter, for tapering the two opposite sides of the bar, after the journal and collar have been formed; and at the terminus of each of these cams, a projecting edge, to act as a cutter, these two cutters, marked *d*, meeting at their edges near enough to cut off the finished axle from the blank.

The grooves *a* are made a quarter circle, transversely, and act in conjunction with corresponding grooves in the horizontal rollers, hereinafter described, all these four grooves expanding gradually, both in breadth and depth, from their forward to their rear ends. The grooves *b* are made each a half circle, transversely, and also expand similarly in breadth and depth, but the horizontal rollers have no corresponding grooves. The parts in which these grooves are formed are of segmental form, and removable and changeable,

On each of the horizontal shafts, and on each side of the cog-wheels which embrace the shaping-rolls, is placed a sliding and adjustable sleeve, I I, cut square in its bore, so as to be revolved by the shaft, but made cylindrical on its periphery, to receive a surrounding sleeve, K, not designed to revolve with it. Each of these sleeves has a tubular projection, L, to serve as a socket or bearing, within which revolve the shafts or axes of the horizontal rolls. These latter have a circular series of teeth or pins, e, on their upper side or face, by means of which they are caused to revolve simultaneously with the vertical rolls, through the action of the cog-teeth, which are on either side of the upper roll.

A loose and removable disk, M, is placed between the sleeves K and the hubs of the cog-wheels F'. When larger or smaller shaping-rolls are to be substituted, for the purpose of making axles of a different size or pattern, larger or smaller disks, (in thickness,) or more of them, or none at all, are used, as the length of the hub of the roll and its cog-wheels may require.

The sleeves I are arranged to slide in other sleeves, N, which have flanges both inside and outside of the framework of the machine. Corresponding flanges, on the outer ends of sleeves I, are connected to these by means of a pair of adjusting-screws, O, which, entering threaded eyes on each of the flanges, serve to hold the sleeves I firmly in the position to which they need to be adjusted to or from the central line of the machine, in order to adapt them to the change of the shaping-rolls, and correspondingly to the distances apart that the axes of the horizontal rolls must of necessity be shifted when such change takes place. Proper nuts upon these screws, placed on one side of one of the eyes, hold them fixedly in the positions to which they may be adjusted, and a square or other head to the screws admits of their being readily turned, as desired, by a key or any appropriate tool.

Upon the face of one of the cog-wheels, P, on the shaft E, are inserted two projecting pins, Q. R is a locking spring-lever, having its fulcrum at S, and free to move back and forth in a slot in a supporting-bracket, T, secured to any portion of the machine in any proper manner. A spring, U, exerts a constant pressure against this lever, to press it towards the path of these pins, and, when they are not in contact with it, the extent of its motion, under the action of the spring, is limited by the slot.

A swell, V, and notch W, shaped substantially as shown in Figure 3, allow the pins to force back the lever, to cause it abruptly and quickly to catch a pin, and thus aid in arresting the movement of the wheel P, and so bring the motions of the machine to a stop, after power is thrown off, (by loose-pulley or any other ordinary stop-motion,) these stoppages being necessary at the different stages of forming the different parts of the axle, and also preceding the reverse motions hereinafter alluded to, for the latter-named motion the counter-shaft and its pulley being applied to the machine, as shown.

The lever R has a handle, that the attendant may have it under control, and the lower face of notch W should be so shaped as that, when a pin is in it, it is positively locked against a back or reverse movement, but, by reason of its upward incline or curvature, W, not against a movement in the forward direction, when, in starting, the belt may be again shifted to the fast pulley.

In front of the shaping-rolls, and sliding in grooves or ways in the frame, is a sliding cross-bar, X, and which may be adjusted to a position near to or away from the rolls, as desired, by means of a hand-lever, Y, and a connecting-bar or yoke, Z, both of which are supported and play in guides secured to the frame. In the centre of this cross-bar, and in a line with the path of the metal bar, as it passes between the rolls, is a square socket for the reception of a solid square die, 1, through which the journal of the axle, when formed, and tapered, passes, and it is between this die and another solid but tubular die, 2, that the collar of the axle is formed, by violent compression, as hereinafter stated. This square die is removable, in order to change it for one of different size or form, according to the size and character of the axle to be made. In the forward end of this square die, rebates are cut in its outer surface, to admit of its being placed in close proximity to the rolls, without risk of coming in contact with them, or interfering with their revolutions. One of these dies is shown, detached, in Figure 8.

A hinged gate, 3, formed substantially as shown, serves, in connection with the cross-bar of the framework, to which it is hinged, to hold in horizontal position, when in action, the sliding barrel, which carries the tubular die. A chain and pin, and suitable eyes, or other equivalent means, serve to lock the gate in place.

In front of the main frame, but connected with and forming a continuation of it, is the framework which supports the sliding tubular die 2, and the machinery for operating it. This die is also removable, and may be changed for one of different size, length, or pattern. It is preferably made with an enlargement in its bore at the mouth, the object of which is to produce upon the journal, immediately next to the collar, a corresponding enlargement or "swell." This die is inserted in a swinging tube or barrel, 4, its outer end being provided with a flange, which, when it is in place, fits snugly against the end of the tube. This barrel pivots or swings on a centre rod, secured to slides 5, which run in two parallel ways or grooves, 6, in the sides of the auxiliary frame.

In the rear of the same grooves runs another slide, 7, to which is hinged or centred one end of the arm of a strong toggle-joint, 8, whose other arm is centred on the same rod with the swinging barrel. These two arms of the toggle are made broad and strong, and at their point or line of junction, 9, are connected by a crank-rod or pitman, 10, with a crank, 11, on a cross-shaft, 12, supported in the auxiliary frame.

In the rear of the barrel is introduced, lengthwise, a capstan-headed screw, 13, whose inner extremity is furnished with a hard central point or pin, the object of which is to indent a central depression in the end of the journal of the axle, as hereinafter described. This screw, working within a corresponding screw-thread in the bore of the barrel, admits of being adjusted to adapt itself to dies of different sizes, and serves also firmly to hold the bar against the violent pressure to which it is to be subjected.

In the front cross-bar of the auxiliary frame, and about at its centre, is placed another adjusting-screw, 14,

the inner end of which serves to limit the backward motion of the toggle and slides, and to determine the extent of such motion.

Instead of this toggle (but not so powerful and efficient in its action) may be employed a screw, 15, passing through the rear cross-bar of the auxiliary frame, and also turning freely in the sliding frame, as shown in Figure 9, and having a flat disk or button on its inner end. By turning this screw, the barrel may be forced forward, and held firmly in the position desired; and by reversing the motion of the screw, the barrel and the frame in which it swings are brought back again, as desired. The head of the screw, whilst free to revolve in the cross-bar, has no longitudinal movement therein.

The operation of the machine is as follows: The parts of the machine being all in the relative positions, as shown in fig. 3, the hinged gate 3 and the swinging barrel being raised, and the vertical rolls in a position somewhat in advance of that shown in Figure 7, the blank bar of metal is passed by the workman into the mouth in cross-bar D far enough to place its forward end into the space between the rolls, and so that this end shall coincide with the smaller or commencing ends of the grooves *a*. The machine is then put into operation, and the rolls turned far enough to draw in the bar and take off or reduce its four corners or edges, as shown in the figure, by the pressure of the rolls upon them.

At this stage, the notched spring-lever R flies into place to hold the pin 2 upon the face of cog-wheel P, and arrest its further revolution, at the same time that the forward motion is stopped by the belt-shifter. The movements of the machine are then reversed, and this causes the rolls to run back the bar upon which they are operating to free it from the grasp of the grooves. The belt is again shipped, and a forward motion of the rolls takes place, and just as the grooves *b* meet at their forward ends (the bar being properly held in position for this purpose) they seize and gripe the bar, and the "arm" of the axle is now rolled to the proper conical or taper form, thus rounding off the corners left by the grooves *a*. Cross-bar X, with its solid square die, is now brought up, so that the die shall be in close proximity to the bite of the rolls, and is secured in this position. The barrel (with its tubular die first inserted therein) is now let down. The hinged bar or gate is closed over it and locked to its place, and this barrel having been advanced to the proper position to receive the "arm" of the metal bar, and yet to leave sufficient space between the dies 1 and 2 for the formation of the collar, and the screw 13 being properly adjusted for "centring" the arm, power is applied either to the toggle-joint, or to the screw 15, when that is used, and this further advance of the barrel towards the die violently and surely compresses the bar lengthwise, and compels it to yield and spread laterally in every direction, the firm grasp of the rolls, which are now stationary, holding the bar rigidly against the pressure of the barrel. This action produces the collar, and at the same time the enlargement or swell on the collar, and also centres the end of the journal. The degree of thickness of the collar will be determined by the adjustment of the screw 14 or 15 at the outer end of the auxiliary frame, such adjustment regulating the stroke of the toggle or oblique engine.

The machine is designed to be operated by two men, one to insert the bar and to start and stop the machine, as required, and one at the side to operate the side lever Y, and the machinery for forming the collar. After the hinge is thrown down and fastened, and power applied to the toggle, one revolution of the shaft which operates it, forms the collar and swell, and withdraws the die from the journal of the axle. The hinged barrel is then again thrown up, as shown in fig. 3, and the die 2 thrown back, and at the same time the machine is again started, and, as the axle is thus rolled forward by the movement of the rolls, the cross-bar X, with its die 1, is drawn back clear of the rolls, the action of the cams *c* on the rolls, at this stage, forming the requisite flat taper towards the end of the required axle, which is then cut off, as before described, and falls to the ground, the rolls still continuing to revolve until they arrive at the proper position for commencing their action upon the bar to form another axle.

It will be observed that by means of the provision described for changing the size or style of the rolls, and also of the dies, the same machine is adapted to a great variety of work without any change in its principle of action, or in its general construction.

The advantages of solid dies over those which are sectional in the direction of their bore, and which have hitherto been used in forming the collar of an axle, are great and material. When made in parts, these parts are liable to get displaced, so that their ends are not flush with each other, and they must then make an imperfect collar. They are also liable to become separated from each other by the pressure when in action, so as to leave more or less space between them, and so make imperfect work; and they also require additional devices to be introduced into the machine in order to clamp or press these parts together, and such pressure must be always accurately adjusted. Further, when such parts are not in closest contact, and under the proper amount of pressure, a square die would give rather an oblong than a square form, and a round die an oval rather than a cylindrical form to the metal.

What I claim, and desire to secure by Letters Patent, is—

1. The combination of the shaping-rollers, which form the journal and taper the bar of an axle, with the dies which form the collar by lengthwise pressure of the bar, substantially as described.
2. A pair of rolls, for acting simultaneously on opposite surfaces of a bar of metal, having dies, *a b c*, arranged in relation one to the other and to the rolls, substantially as herein set forth.
3. In combination with the die-rolls claimed in the above second clause, I claim the cutting-edge *d*, as described.
4. In combination with the die-rolls claimed in the above second clause, I claim a pair of rolls arranged perpendicularly thereto, and for joint action therewith, substantially as described.
5. In combination with a pair of die-rolls, I claim the devices, herein described, for accommodating dies of more or less thickness, substantially as set forth.

6. Mounting one set of rolls upon vertical shafts, which revolve in bearings upon sleeves on the other shaft, substantially as and for the purpose described.

7. In combination with die 2 and socket 4, or their equivalents, I claim the pointed screw 13, as and for the purposes set forth.

8. The improved machine as a whole, constructed and operating substantially as set forth.

BENJ'N W. FOSTER.

Witnesses:

A. B. SHELDON,
RICHARD C. STEEL.